

SMD5050

White SMD LED

Features

1. Package: 5.0*5.0*1.6mm (TOP view white LED)
2. Emitted Color: White
3. Mono-color type
4. Soldering methods: All SMT assembly methods
5. Comply ROHS standard

Applications

1. LCD back light.
2. Mobile phones: LCD,
3. Status indicators: Consumer&industrial electronics
4. General use

Absolute Maximum Ratings(Ta=25°C)

Parameter	Symbol	Rating	Unit
Power Dissipation	Pd	180	mW
Forward Current	IF	60	mA
Peak Forward Current *1	IFP	180	mA
Reverse Voltage	VR	5	V
Soldering Temperature	Tsol	260 (for 5 sec)	°C
Operating Temperature	Topr	-30 - 85	°C
Storage Temperature	Tstg	-40 - 85	°C
Electrostatic discharge	ESD	2000	V

*1 IFP condition: pulse of 1/10 duty and 0.1ms width

Absolute Maximum Ratings(Ta=25°C)

Parameter	Symbol	Rating	Unit
Power Dissipation	Pd	100	mW
Forward Current	IF	20	mA
Peak Forward Current *1	IFP	100	mA
Reverse Voltage	VR	5	V
Soldering Temperature	Tsol	260 (for 5 sec)	°C
Operating Temperature	Topr	-30 - 85	°C
Storage Temperature	Tstg	-40 - 85	°C
Electrostatic discharge	ESD	2000	V

*1 IFP condition: pulse of 1/10 duty and 0.1ms width

Electrical-optical characteristics(Ta=25°C)

Parameter	Symbol	Min.	Typ.	Max.	Unit	Condition
Forward Voltage	Vf	3.0		3.4	V	IF=60mA
Luminous Intensity	Lm	12	13	15	lm	
Luminous Intensity	Iv	4000		5000	mcd	
Viewing Angle	2θ 1/2		140		deg	
Reverse Current	IR				μA	VR=5V

Note: 1. Tolerance of luminous intensity is ± 10%
2. Tolerance of forward voltage is ± 0.05V

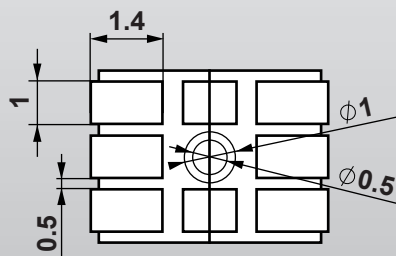
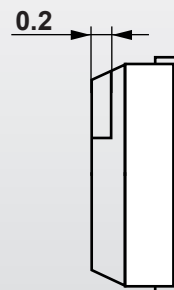
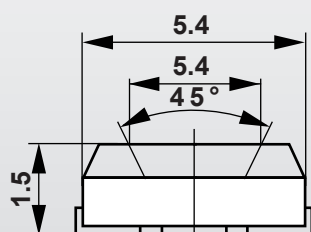
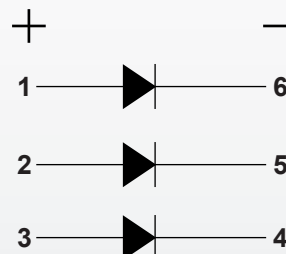
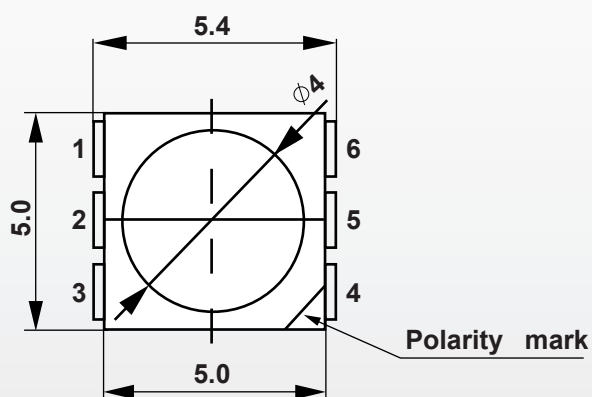

Reliability test items and conditions

No.	Test Item	Test Conditions	Sample	Ac/Re
1	Operation Life	Test If=DC60mA Temp: Room temperature Test time=1000hrs	22	0/1
2	High Temperature High Humidity	Temp. =+85°C RH=85%HR Test time=1000hrs	22	0/1
3	Thermal Shock	-35°C ~ +85°C 20min 10s 20min Test Time=300cycles	22	0/1
4	High Temperature Storage	High Temp. =+85°C Test time=1000hrs	22	0/1
5	Low Temperature Storage	Low Ta=-35°C Test time=1000hrs	22	0/1
6	Temperature Cycle	-35°C ~ +100°C 15min 5min 15min Test Time=300cycle	22	0/1
7	Reflow Soldering	Operation heating: 260°C(Max.), within 10seconds. (Max.)	22	0/1

Judgment criteria of failure for the reliability

- Iv: Below 50% of initial values
- Vf: Over 20% of upper limit value
- IR: Over 2 times of upper limit value

Note: Measurement shall be taken between 2 hours and after the test LED have been returned to normal ambient conditions after completion of each test

Precautions for use

1. Customer must apply the current limiting resistor in the circuit so as to drive the LEDs within the rated current. Otherwise slight voltage shift maybe will cause big current change and burn out will happen
2. Also, caution should be taken not to overload the LEDs with instantaneous high voltage at the turning ON and OFF of the circuit
3. Storage:
 - 3.1 Don't open the moisture proof bag before ready to use the LEDs
 - 3.2 The LEDs should be kept at 30°C or less and 60%RH or less before opening the package
The max. storage period before opening the package is 1 year
 - 3.3 After opening the package, the LEDs should be kept at 30°C/35%RH or less, and it should be used within 7 days
 - 3.4 If the LEDs be kept over the conditions of 3.4, baking is required before mounting.
Baking condition as below: 60±5°C for 12 hrs
4. Soldering condition:
 - 4.1 Manual of soldering:
The temp. of the iron should be lower than 280°C and soldering within 3sec per solder-pad is to be observed
 - 4.2 Pb-free solder temp. –time profile

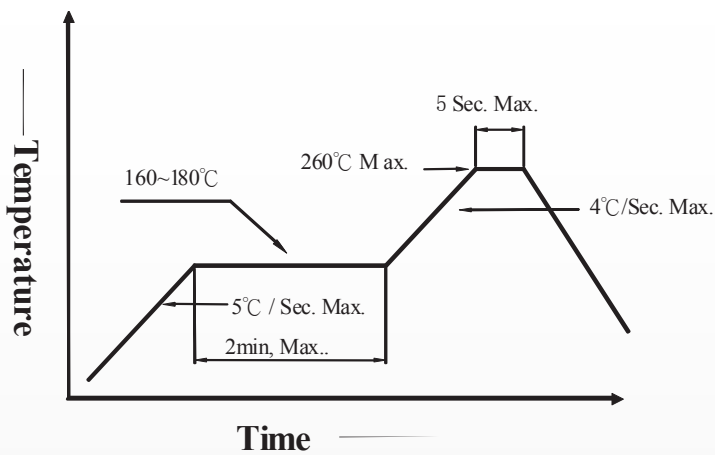

4.3 DIP soldering (Wave Soldering) temp. -time profile:

Note: a) Reflow soldering should not be done more than two times.

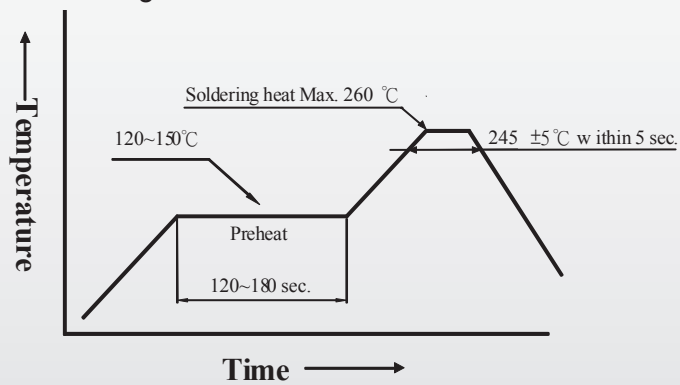

- b) Don't put stress on the LEDs when soldering.
- c) Don't warp the circuit board before it have been returned to normal ambient conditions after soldering.

Loaded quantity: 1000 pcs/reel

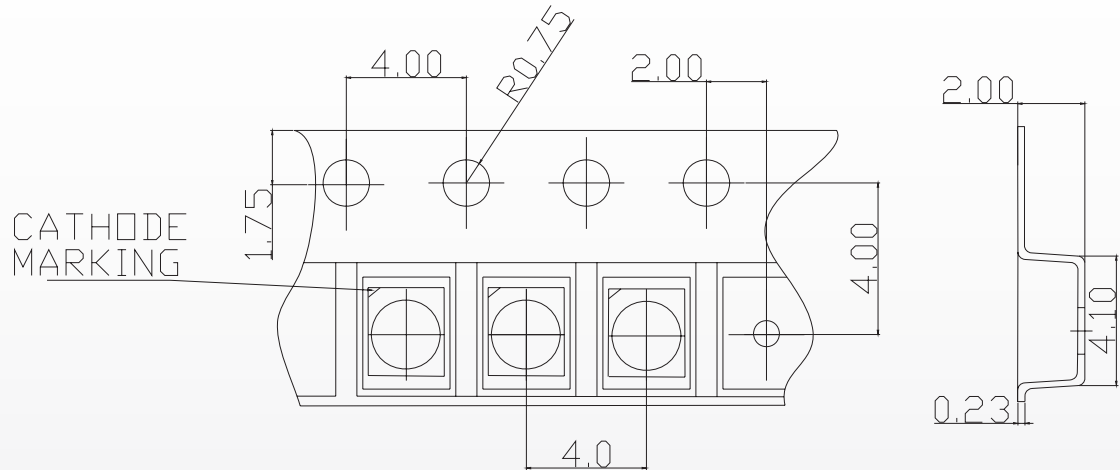

Package Method:(unit:mm)

